

# CONSIDERATIONS FOR FUTURE IGS RECEIVERS

TODD HUMPHREYS, LARRY YOUNG, AND THOMAS PANY

ABSTRACT. Future IGS receivers are considered against the backdrop of GNSS signal modernization and the IGS's goal of further improving the accuracy of its products. The purpose of this paper is to provide IGS members with a guide to making decisions about GNSS receivers. Modernized GNSS signals are analyzed with a view toward IGS applications. A schedule for minimum IGS receiver requirements is proposed. Features of idealized conceptual receivers are discussed. The prospects for standard commercial receivers and for software-defined GNSS receivers are examined. Recommendations are given for how the IGS should proceed in order to maximally benefit from the transformation in GNSS that will occur over the next decade.

## 1. INTRODUCTION

There are two reasons why it makes sense for the IGS to study GNSS receivers that will be integrated into its network in the coming years. First, the new GNSS signals that will come on line over the next decade will render current IGS receivers obsolete, so it is prudent to examine receiver options going forward. Second, the push to improve the accuracy of IGS products beyond current limits demands greater accuracy in the models used to describe receiver measurements. As a result, the IGS must demand from vendors more transparency into receiver firmware or adoption of user-specified algorithms.

This paper considers future IGS receivers from four different points of view. Section 2 looks at modernized GNSS signals and their benefits for the IGS. Section 3 surveys the range of expected receiver capability. Section 4 considers current and future commercial geodetic-quality receivers. Section 5 considers software GNSS receivers as an alternative to less reconfigurable traditional receivers. Section 6 lays out the authors' recommendations to the IGS.

## 2. SIGNALS AND PERFORMANCE

GPS modernization is underway. Six signals are currently being broadcast from modernized GPS satellites; a seventh signal is scheduled for on-orbit transmission before the end of 2008. Of the six current signals, two are the new military signals, M1 and M2, which cannot be tracked by unauthorized receivers. The other four are the C/A signal at L1 (1575.42 MHz) and the L2C signal at L2 (1227.6 MHz), which can be tracked using open codes, and the two encrypted P(Y) signals transmitted at both L1 and L2, which can be tracked by unauthorized receivers only if the receivers employ codeless or semicodeless correlation techniques. The seventh signal, a broadband civil signal, will be broadcast at L5 (1176.45 MHz). Another civil signal, L1C at L1, will be available with the first GPS III satellites.

The rollout schedule shown in Fig. 1 reflects an optimistic estimate of L2C and L5 availability. The 18 L2C-capable satellites already on orbit or manifested for launch, of which 10 are also L5-capable, offer exciting near-term opportunities to improve IGS products.

The GLONASS constellation transmits four signals roughly corresponding to GPS C/A, P(Y) (L1), L2C, and P(Y) (L2), although at distinct carrier frequencies somewhat displaced from L1 and L2.

---

Todd Humphreys is with the Sibley School of Mechanical and Aerospace Engineering, Cornell University, Email:(teh25@cornell.edu).

Larry Young is with NASA's Jet Propulsion Laboratory, Email:(Lawrence.E.Young@jpl.nasa.gov).

Thomas Pany is with University FAF Munich, Email:(thomas.pany@unibw.de).

**2008 IGS Workshop, Miami Beach, FL.**

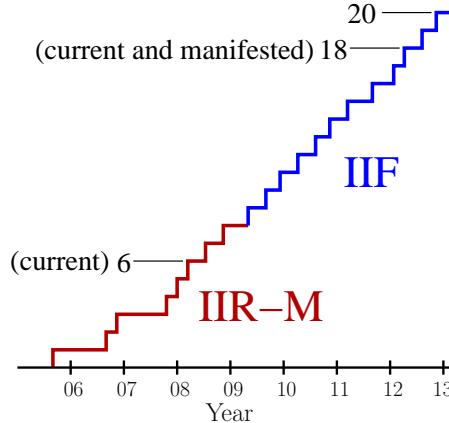

FIGURE 1. Optimistic schedule for rollout of L2C-capable GPS satellites. Block IIF satellites will also broadcast the new L5 civilian signal.

GLONASS signals are displaced in frequency for different satellites, which causes difficulties for high-precision users because instrumental delays and phase shifts are not common among satellites tracked by the same receiver owing to the distinct instrumental effects at each satellite frequency.

When Galileo begins transmitting, a rich set of at least six additional signals will be available at or near L1, L5 (called E5a and E5b), and E6 (1278.75 MHz).

What makes for good signals for science applications?

## 2.1. Carrier Frequency.

2.1.1. *Minimizing Errors in the Iono-Free Linear Combination.* The (first-order) ionosphere-free linear combination of pseudorange measurements  $\rho_1$  and  $\rho_2$  from signals at frequencies  $f_1$  and  $f_2$  is given by

$$\rho_{IF} = \left[ 1 + \frac{f_2^2}{f_1^2 - f_2^2} \right] \rho_1 - \left[ \frac{f_2^2}{f_1^2 - f_2^2} \right] \rho_2$$

To reduce the magnification of measurement errors in  $\rho_1$  and  $\rho_2$  by this linear combination, the factor  $f_2^2/(f_1^2 - f_2^2)$  should be made as small as possible. For a dual-frequency combination of current and planned GNSS carrier frequencies, this requirement suggests the selection of L1 and L5/E5a.

2.1.2. *Trilaning.* The use of combinations of carrier phase observables to estimate carrier ambiguities should be considered. In particular, by using three carriers, a new technique called trilaning becomes possible. If it assumed that a triple-frequency selection must include L1, L5, and an intermediate frequency, then the proposed frequency for Galileo E6 is near optimum for trilaning.

To see this, suppose signals from L1, E6, and L5 are available so that widelane observables from L1-E6 and E6-L5 phases can be formed. Let these widelane observables be compared with those obtained using L1, L2, and L5 to see what is gained by using E6. Assume double-differenced measurements in this discussion.

The first step is to use pseudoranges to resolve the widelane ambiguities. If the pseudoranges are assigned 10 cm errors, and carrier phase measurements have 1 mm error, widelane ambiguities can successfully be estimated to  $< 1/6$  cycle for both the L1/L2/L5 and L1/E6/L5 cases. (A  $1/6$  cycle criterion is used because it yields a 3-sigma probability of selecting the correct integer ambiguity.)

The next step is to select two widelane observables and form the ionosphere-free combination. There is a multiplier between the error in individual phase measurements and the ionosphere-free range formed from three carrier phase measurements, resulting in the overall range error  $\Delta\rho$  given in Table 1 for the L1/L2/L5 and L1/E6/L5 cases.

TABLE 1. Ionosphere-free trilane error  $\Delta\rho$  for three trilane options

Carrier Frequency ( $\times 10.23$ MHz)			
L1	L5	L2, E6, or CS	$\Delta\rho$ (cm)
154	115	120 (L2)	11.0
154	115	125 (E6)	6.7
154	115	500 (C-band)	0.3

2.1.3. *C-band GNSS Signal.* At least one of us favors investigation of a GNSS signal at a frequency much higher than those currently in use, near 5115 MHz for example. A signal at this frequency could be used to form very precise carrier phase observables in a regime where the ionospheric effect is much smaller. Smart, actively steered arrays could be built that are close to the size of today’s L-band hemispherical antennas but would allow multiple beams toward the satellites and null forming toward multipath sources.

## 2.2. BPSK Code Modulation.

2.2.1. *Chipping Rate.* There are two main advantages to higher chipping rates:

- (1) For a given ratio of signal bandwidth to chipping rate, the errors due to receiver (thermal) noise are inversely proportional to the chipping rate. Figure 2 compares the ranging precision of modernized GPS signals in the presence of white receiver noise as a function of the L1 C/A carrier-to-noise ratio ( $C/N_0$ ). Typical L1 C/A  $C/N_0$  values for elevation angles above 10 degrees range from 37 to 53 dB-Hz. Signal power levels consistent with Block IIR-M and IIF GPS satellites are assumed, i.e., relative to L1 C/A, L2C is 1.5 dB below, L1 P(Y) and L2 P(Y) are 3 dB below, and L5 (either I5 or Q5) is 3.6 dB above. A squaring loss commensurate with the near-optimal linear approximation to the MAP carrier recovery technique introduced in [1] is assumed (modified to account for the increased L2 P(Y) signal power transmitted by the modernized GPS satellites). The squaring loss is reflected in the relatively steeper slope of the P(Y) curve in Fig. 2.

The benefit of the higher chipping rates of the P(Y) and L5 signals—ten times that of the L1 C/A and L2C signals—is obvious. Even when weakened by the squaring loss due to lack of knowledge of the W-bits, semicodeless tracking of the P(Y) signals on L1 and L2 results in smaller ranging errors than for L1 C/A and L2C above an L1 C/A  $C/N_0$  of approximately 47 dB-Hz. Of course, the L5 signal, which combines higher power with a faster chipping rate, has the best ranging precision of the group, delivering an approximate 5-fold improvement over L1 C/A and L2C.

- (2) Multipath is a more complex issue. For multipath sources whose additional delay is less than about half the lag spacing (which is usually half a chip), the multipath error is the same for all chipping rates, as shown in Fig. 3. The strongest multipath signals come from nearby sources at IGS sites, since scattering losses are proportional to the distance squared. Furthermore, distant multipath signals fluctuate more rapidly so that the resulting errors average down quicker than errors from nearby sources. It is known that nearby sources can add a systematic signature aliasing into the local vertical and tropospheric estimates, but less is known about the effects of distant sources on estimated parameters at IGS sites. We recommend that studies be performed to determine whether multipath from signals delayed by more than 40 ns (approximately 12 m) contributes significantly to errors in the estimated parameters at IGS sites.

2.2.2. *Pilot Signals.* Many of the new GPS and Galileo codes will have a “pilot” component. These signals carry no data bits, and so coherent integrations can be made over long intervals to allow easier

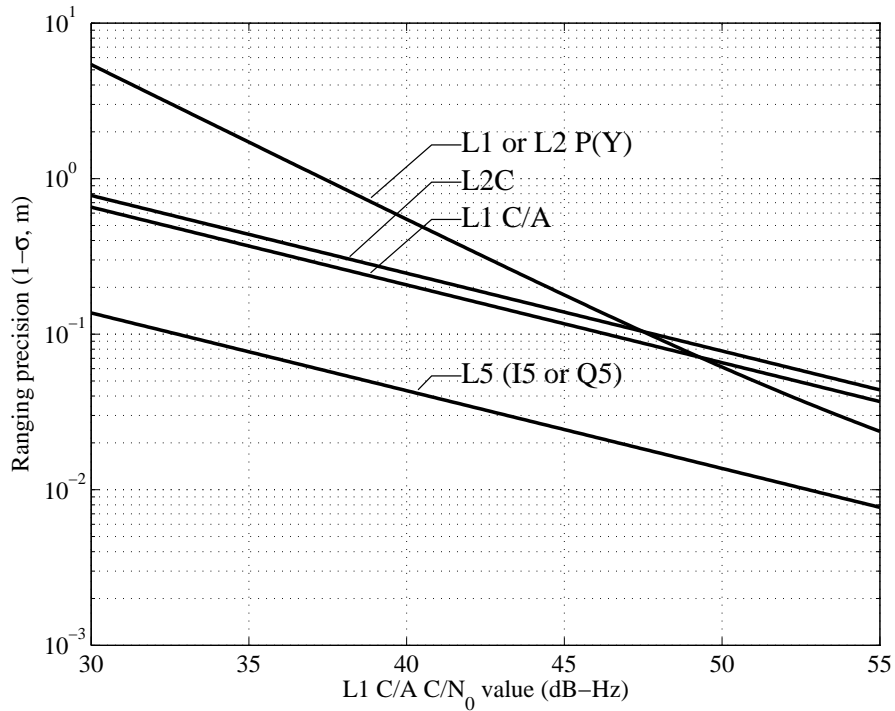

FIGURE 2. Ranging precision of modernized GPS signals in the presence of white receiver noise as a function of the L1 C/A carrier-to-noise ratio ( $C/N_0$ ). Signal power levels consistent with Block IIR-M and IIF GPS satellites are assumed, i.e., relative to L1 C/A, L2C is 1.5 dB below, L1 P(Y) and L2 P(Y) are 3 dB below, and L5 (either I5 or Q5) is 3.6 dB above.

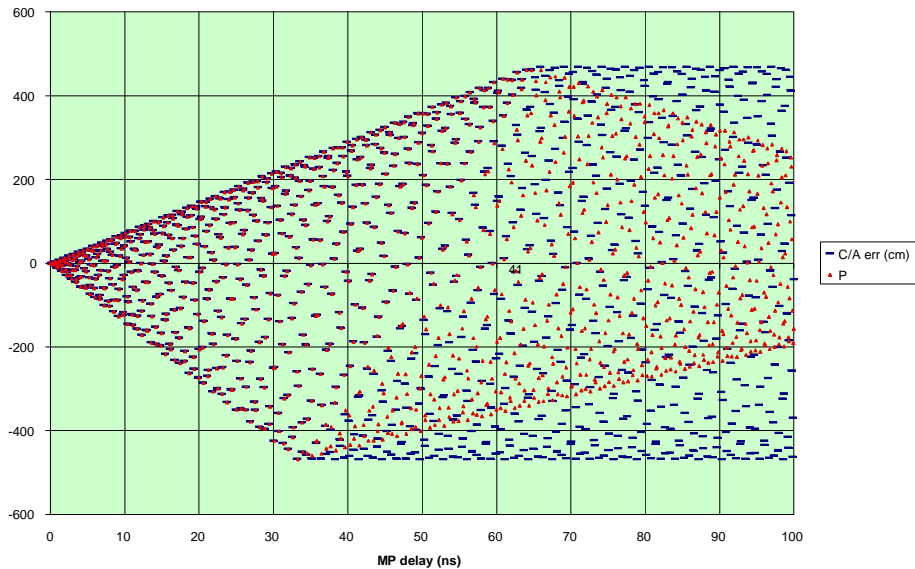

FIGURE 3. C1 and P1 multipath error comparison assuming an early-minus-late correlator spacing of 97.8 ns and a multipath component whose power is 10 dB below that of the direct component. Multipath error is expressed in cm.

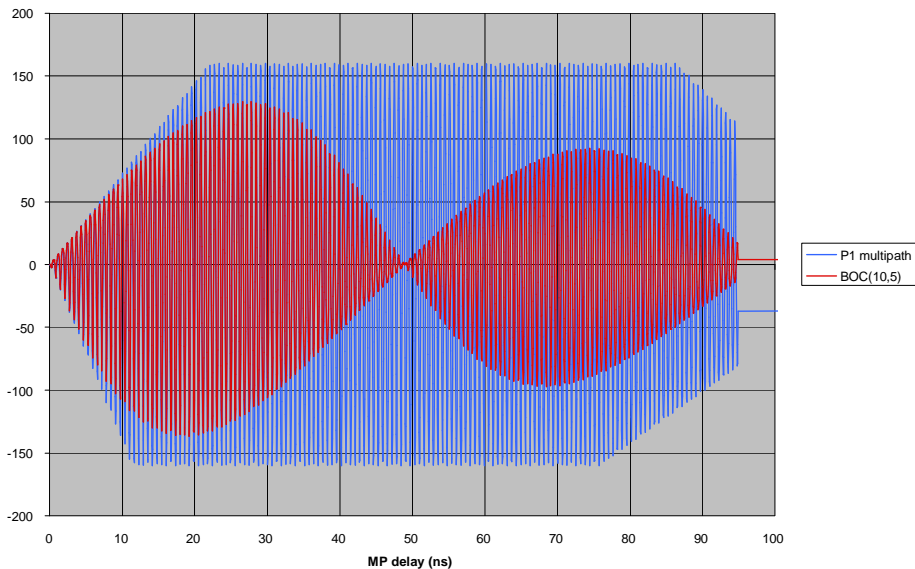

FIGURE 4. P-code and BOC(10,5) multipath error comparison assuming an early-minus-late correlator spacing of 32 ns and a multipath component whose power is 10 dB below that of the direct component. Multipath error is expressed in cm.

acquisition of weak signals. Moreover, because pilot signals allow full-cycle carrier tracking, whereas bi-phase modulated channels allow only half-cycle tracking, the tracking precision required to avoid carrier slips in the pilot tone tracking loop is reduced by about 6 dB. This translates into a 6-dB reduction in the tracking threshold, which will make tracking through weak signals and through ionosphere-induced scintillation more robust.

2.2.3. *Coded vs. Semicodeless Tracking.* Use of semicodeless processing has given science users access to dual frequency signals in the past. Now that civil signals are beginning to be available at L2 as well as at L1, and will soon be available at L5, one can consider the relative advantages of coded vs semicodeless tracking.

- (1) Coded tracking has the advantage of higher signal-to-noise ratio (SNR) for equivalent received  $C/N_0$ , allowing better acquisition and tracking in challenging conditions.
- (2) At high  $C/N_0$  values, semicodeless tracking of higher rate codes can yield smaller ranging errors due to receiver noise than coded tracking of lower rate codes (cf. Fig. 2).

2.3. **BOC and Multiplexed BOC Signals.** These new signals will be exciting to exploit, obtaining the advantages of high chipping rate BPSK codes (better precision and lower multipath for long multipath delays) by the use of two or more subcarriers. Figures 4 and 5 compare P-code and BOC(10,5) code and carrier multipath. In addition, we anticipate that clever people will find unexpected ways to exploit the unique observables that BOC and MBOC codes produce.

### 3. CHARACTERISTICS OF FUTURE IGS RECEIVERS

This section considers a range of GNSS receiver capability, extending from the minimum that the IGS currently allows to the maximum imaginable that still lies within the reach of practical implementation. As aids to discussing the upper limits of practical capability, two conceptual receivers are introduced—the Super and Ultra receivers.

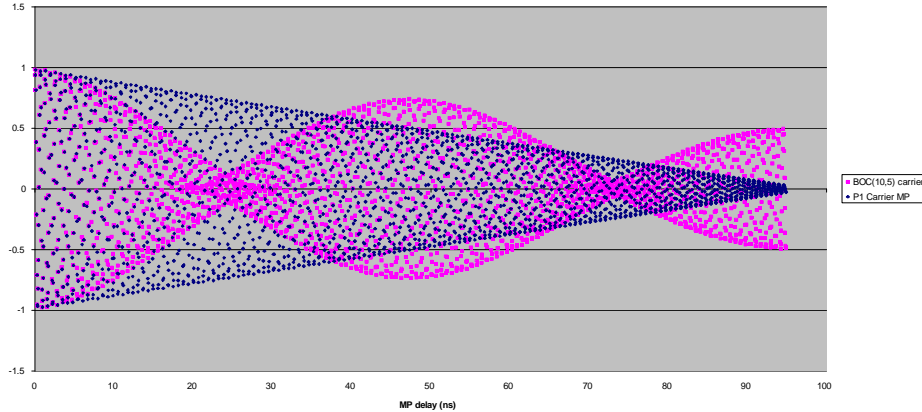

FIGURE 5. P-code and BOC(10,5) carrier multipath error comparison assuming an early-minus-late correlator spacing of 32 ns and a multipath component whose power is 10 dB below that of the direct component. Multipath error is expressed in cm.

**3.1. Minimum Receiver Requirements.** Current (June, 2008) minimum required observables for IGS receivers are summarized in Table 2 in terms of both the RINEX 2.11 and 3.00 standards. In this table, ‘or’ is meant to be inclusive; e.g., C1 or P1 implies at least one of C1 and P1. It is further assumed that in the absence of antispoofing, all receivers track P-based observables directly; i.e., via autocorrelation with the known P-code. For convenience, observation code conventions for the RINEX 3.00 standard are given in Fig. 6.

TABLE 2. Current minimum required observables for IGS receivers

RINEX 2.11	RINEX 3.00
L1	L1C or L1P or L1W or L1Y or L1N
L2	L2C or L2D or L2S or L2L or L2X or L2P or L2W or L2Y or L2M or L2N
P2	C2D or C2P or C2W or C2Y
C1 or P1	C1C or C1P or C1W or C1Y

Over the next decade or so, these minimum requirements must be updated to ensure that the IGS fulfills its mission as the “premier source of the highest-quality GNSS related standards (conventions), data, and products” (IGS Strategic Plan 2008-2012). Not only will the IGS want to exploit new GNSS signals as they come on line, but it must also adapt to the recent announcement that the U.S. Air Force intends to discontinue codeless and semicodeless access to the encrypted P(Y) signals on L1 and L2 by approximately 2020 (see IGS Mail 5774).

In proposing updates to the minimum receiver requirements, the IGS must temper its desire to remain current with a recognition that abrupt, sweeping requirement changes are not appropriate for a loose volunteer federation such as the IGS. It would not be prudent, for example, to require that all receivers in the IGS network be L2C-capable by 2009. The following proposed requirements changes represent, in the authors’ judgment, a sensible requirements update schedule for the IGS. According to this schedule, minimum requirements changes are linked to specific events, not to calendar dates. Changes listed under each event are relative to the current requirements at the time the event occurs. In other words, after each event all the previous requirements apply plus those specified for the event. Events A1, A2, and A3 will occur in that order, but the full chronology of events Ax through C is not

System	Freq. Band	Frequency	Channel or Code	Observation Codes			
				Pseudo Range	Carrier Phase	Doppler	Signal Strength
GPS	L1	1575.42	C/A	C1C	L1C	D1C	S1C
			P	C1P	L1P	D1P	S1P
			Z-tracking and similar (AS on)	C1W	L1W	D1W	S1W
			Y	C1Y	L1Y	D1Y	S1Y
			M	C1M	L1M	D1M	S1M
	codeless	--	L1N	D1N	S1N		
	L2	1227.60	C/A	C2C	L2C	D2C	S2C
			L1(C/A)+(P2-P1) (semi-codeless)	C2D	L2D	D2D	S2D
			L2C (M)	C2S	L2S	D2S	S2S
			L2C (L)	C2L	L2L	D2L	S2L
			L2C (M+L) <sup>1</sup>	C2X	L2X	D2X	S2X
			P	C2P	L2P	D2P	S2P
			Z-tracking and similar (AS on)	C2W	L2W	D2W	S2W
			Y	C2Y	L2Y	D2Y	S2Y
	M	C2M	L2M	D2M	S2M		
	codeless	--	L2N	D2N	S2N		
	L5	1176.45	I	C5I	L5I	D5I	S5I
			Q	C5Q	L5Q	D5Q	S5Q
I+Q			C5X	L5X	D5X	S5X	
GLONASS	G1	1602+k*9/16	C/A	C1C	L1C	D1C	S1C

		k= -7...+12	P	C1P	L1P	D1P	S1P
	G2	1246+k*7/16	C/A (GLONASS M)	C2C	L2C	D2C	S2C
Galileo	E1	1575.42	P	C2P	L2P	D2P	S2P
			A PRS	C1A	L1A	D1A	S1A
			B I/NAV OS/CS/SoL	C1B	L1B	D1B	S1B
			C no data	C1C	L1C	D1C	S1C
			B+C	C1X	L1X	D1X	S1X
	A+B+C	C1Z	L1Z	D1Z	S1Z		
	E5a	1176.45	I F/NAV OS	C5I	L5I	D5I	S5I
			Q no data	C5Q	L5Q	D5Q	S5Q
			I+Q	C5X	L5X	D5X	S5X
	E5b	1207.140	I I/NAV OS/CS/SoL	C7I	L7I	D7I	S7I
			Q no data	C7Q	L7Q	D7Q	S7Q
			I+Q	C7X	L7X	D7X	S7X
	E5 (E5a+E5b)	1191.795	I	C8I	L8I	D8I	S8I
			Q	C8Q	L8Q	D8Q	S8Q
			I+Q	C8X	L8X	D8X	S8X
	E6	1278.75	A PRS	C6A	L6A	D6A	S6A
			B C/NAV CS	C6B	L6B	D6B	S6B
			C no data	C6C	L6C	D6C	S6C
B+C			C6X	L6X	D6X	S6X	
A+B+C			C6Z	L6Z	D6Z	S6Z	
SBAS	L1	1575.42	C/A	C1C	L1C	D1C	S1C
	L5	1176.45	I	C5I	L5I	D5I	S5I
			Q	C5Q	L5Q	D5Q	S5Q
			I+Q	C5X	L5X	D5X	S5X

FIGURE 6. RINEX 3.00 observation codes.

currently known. Requirements specifications are expressed in terms of the RINEX 3.00 observation codes (cf. Fig. 6).

**Event A1: 8 or more L2C-capable GPS satellites (~2009).** The following requirements changes apply to receivers newly incorporated into the IGS network after this event:

- (1) Receivers must measure at least one of GPS L2S, L2L, and L2X.
- (2) Receivers must measure at least one of GPS C2S, C2L and C2X.
- (3) Receivers must have the capability of being slaved to an external frequency reference.

**Event A2: 8 or more L5-capable GPS satellites (~2012).** The following requirements changes apply to receivers newly incorporated into the IGS network after this event:

- (1) Receivers are no longer required to measure any of GPS C2D, C2P, C2W, and C2Y.
- (2) Receivers must measure at least one of GPS L5I, L5Q, and L5X.
- (3) Receivers must measure at least one of GPS C5I, C5Q, and C5X.

**Event A3: Discontinuation of codeless or semicodeless access to P(Y) signals (~2020).**

Following this event, the requirements changes applied to newly incorporated receivers after Events 1 and 2 now apply to all receivers in the IGS network.

**Event B: 8 or more Galileo satellites.** The following requirements changes apply to receivers newly incorporated into the IGS network after this event:

- (1) Receivers must measure at least one of Galileo L1A, L1B, L1C, L1X, and L1Z.
- (2) Receivers must measure at least one of Galileo C1A, C1B, C1C, C1X, and C1Z.
- (3) Receivers must measure at least one of Galileo L5I, L5Q, L5X, L8I, L8Q, and L8X.
- (4) Receivers must measure at least one of C5I, C5Q, and C5X, C8I, C8Q, and C8X.

**Event C: 8 or more dual-frequency CDMA GLONASS satellites.** The following requirements changes apply to receivers newly incorporated into the IGS network after this event:

- (1) Receivers must measure at least one of GLONASS L1C and L2P.
- (2) Receivers must measure at least one of GLONASS C1C and C1P.
- (3) Receivers must measure at least one of GLONASS L2C and L2P.
- (4) Receivers must measure at least one of GLONASS C2C and C2P.

**3.2. The Super Receiver.** The Super Receiver is a conceptual GNSS receiver with characteristics that are desirable to the IGS. Its features could be implemented and its observables processed with current technology.

The Super Receiver

- tracks all open signals on all healthy GNSS satellites;
- tracks encrypted signals whenever there is no open signal on the same carrier or whenever their pseudorange precision in the presence of white (receiver) noise is better than that of un-encrypted signals on the same carrier;
- is compliant with the latest RINEX standard;
- is completely user reconfigurable via the Internet, from correlations to tracking loops to navigation solution;
- implements internal cycle slip mitigation and detection;
- produces quadrature correlation products (Is and Qs) for all tracked signals at up to 50 Hz;
- produces observables that can be accessed via the Internet;
- is inexpensive.

**3.3. The Ultra Receiver.** The Ultra Receiver is a conceptual GNSS receiver whose products—while currently impractical to store and process—would represent the highest quality, most useful, most stable GNSS observables imaginable for the IGS.



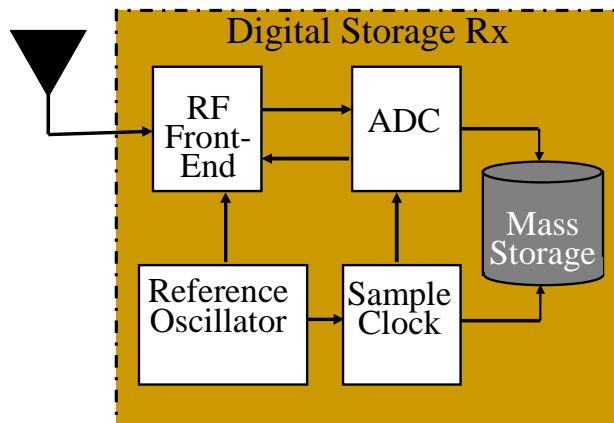

FIGURE 7. A digital storage GNSS receiver: the single-channel component of an Ultra Receiver.

The Ultra Receiver is composed of a bank of digital storage receivers like the one shown in Fig. 7. Each digital storage receiver captures the entire spectral content of a particular GNSS signal by wide-band filtering (and perhaps downconverting) the signal, digitizing it at a sufficiently high sampling rate, and storing the samples to disk. Two-bit sampling quantization would be adequate for foreseeable applications.

The high-sampling-rate data stored to disk could be immediately processed for near-real-time operation; but, more importantly, it could be reprocessed at any later date with the best signal processing strategy of the day. Such a reanalysis of archived GNSS data would have the potential to eliminate from IGS products all effects due to receiver idiosyncrasies and upgrades. The stability of IGS products would then be limited only by the evolution of the network itself (i.e., by the number of sites and their locations).

Of course, a continuously-operating Ultra Receiver is currently impractical for two reasons: (1) data storage requirements would be stupendous and, (2) reprocessing would require large computer clusters or long execution times. Consider, for example, a sub-Ultra Receiver that captures only the GPS L1 C/A signal. For adequate phase stability, a wide passband filter—say, 8 MHz—would be required. To avoid aliasing effects, the bandpass sampling theorem would require a sampling rate of at least 16 Msp. Such a staggering data stream would fill a 1 Tera-byte hard drive (roughly the largest consumer-grade hard drive available today) in less than a week. Reprocessing the stored data using a single CPU could be done presently at about 10 times real time. This would mean that reprocessing 10 years of data from a single station to produce standard receiver observables would require one year on a single computer.

Despite being currently impractical, a continuously-operating Ultra Receiver is not far off, and the IGS would be wise to aspire to it in the coming decades.

#### 4. COMMERCIAL GEODETIC-QUALITY RECEIVERS

This section examines current commercially-available geodetic-quality GNSS receivers from the IGS perspective. Commercial receivers with the reconfigurability and other features of the Super Receiver described above would be of great interest to the IGS. Short of this, the IGS expects at least high-quality dual-frequency range and phase measurements and—so that measurements can be modeled correctly—transparency into the recipe used by each receiver to make such measurements.

To probe the suitability of current commercial receivers for IGS applications, a questionnaire was sent to four GNSS receiver vendors: Septentrio, Trimble, Leica, and Topcon. All four vendors made a serious effort to provide detailed responses to the questionnaire.

These four vendors were chosen because their products are currently the ones most commonly chosen to replace ailing receivers across the IGS network. The following subsection, based on responses to the questionnaire, interviews with IGS members, and the authors’ judgment, gives the outlook for commercial receivers over the next several years. Thereafter, the full questionnaire and responses are presented.

#### 4.1. Outlook.

##### 4.1.1. *Favorable Aspects.*

**Signal tracking capability:** There has been some worry in the past that receiver vendors would not equip their receivers to track modern GNSS signals until a full complement of modern GNSS satellites had been launched. This is not the case. All vendors who responded to the survey offer or will soon offer L2C and L5 capability, dual-frequency GLONASS tracking, and have plans to offer Galileo capability by the time there are a useful number of Galileo satellites (probably around 6) on orbit.

**Internet readiness:** Vendors are offering receivers that support a web page for easy remote receiver monitoring—and in some cases reconfiguration—and an FTP server for data retrieval.

**Reconfigurability:** Septentrio and Leica allow users to reconfigure phase-locked loop (PLL) bandwidths.

**Data quality:** All vendors appear to track GNSS signals with algorithms that are near optimal at high  $C/N_0$  values. The code noise, phase noise, and cycle slipping performance of current receivers—even for semi-codeless recovery of the L2 carrier and P(Y)-based code measurements—appears to be very good (for example, compare the admirable performance of the Septentrio PolaRx2 with the BlackJack “Gold Standard” receiver in [2]).

**Platform:** Current commercial receiver hardware has proven to be generally rugged and reliable.

##### 4.1.2. *Unfavorable Aspects.*

**Measurement definition:** Precision GNSS users must be able to accurately model GNSS receiver measurements in estimation algorithms used to process the measurements. For example, the mean, variance, and time correlation of errors associated with a particular measurement must be accounted for in a measurement model. Such a model is easy to construct if the exact recipe for how measurements are made is known. At the very least, precision users need to know the effective measurement interval to which a given phase, pseudorange, or signal power measurement corresponds. If measurements are made by simply sampling the phase, code, and signal power tracking loops, then the loops’ bandwidths can be used to infer an effective measurement interval.

Trimble, one of the largest vendors of geodetic-quality receivers, was unwilling to disclose essential details about how their receivers’ phase, pseudorange, and signal power measurements are made. Other vendors either disclosed tracking loop bandwidths or have made these configurable.

Even better than knowing tracking loop bandwidths would be persuading vendors to adopt a standard measurement technique, such as the one described in JPL’s recently expired patent “Digital signal processor and processing method for GPS receivers” (U.S. patent 4,821,294). Apparently, NovAtel has adopted the JPL technique for use in their WAAS reference station receivers. Other vendors may follow suit considering the excellent code and carrier tracking properties of the JPL BlackJack receiver, which employs the technique (see [2] for an evaluation of BlackJack code and carrier tracking performance). Such standardization would lead to better measurement models and facilitate combining measurements from different receivers.

**Proprietary output formats:** The Trimble NetR5 receiver outputs data in a proprietary binary format. The IGS finally obtained a conversion utility from Trimble *two years* after an initial request.

**Signal-to-noise ratio reporting:** Most receivers now output a measure of SNR in dB units, which is good, but the quality of the SNR measurement is not uniform among vendors or among signals on a particular receiver. For example, it was reported at the 2008 IGS Workshop that the Trimble NetRS receiver produces noisy L1 C/A SNR measurements but clean L2C SNR measurements. It has also been reported in the literature that the Septentrio PolaRx2 L2 P-code SNR measurement is not accurate [2].

**Limited reconfigurability:** Because of their limited reconfigurability, receivers from commercial vendors do not support some observables and tracking techniques that may be useful to the IGS. For example, as was advanced by Thomas Pany in the 2008 IGS Conference, the IGS would benefit from receivers capable of outputting the complex baseband signal (Is and Qs) associated with each distinct tracked signal. A 50-Hz output rate would be adequate for most applications. Among other uses, such data from two GNSS receivers could be combined to do correlation-level double differencing, a side effect of which is the wipeoff of navigation data bits from the double differences. All GNSS receivers produce this measurement internally, but few commercial receivers make it available to the user.

Consider another example where receiver reconfigurability would benefit the IGS. With the advent of L2C, one could imagine L2C-aided semicodeless tracking of the P(Y) code on L2. The current technique is to use the L1 C/A carrier for aiding, but because the L1 and L2 carrier phases diverge during strong ionospheric events, L2C aiding would lead to a more robust P(Y)-based pseudorange measurement on L2. Apparently, no vendors are currently considering such a tracking strategy. Other exotic tracking techniques that would be useful for tracking weak and scintillating signals are likewise unavailable on commercial platforms.

**4.2. Responses to Questionnaire.** The four GNSS receiver vendors to whom the questionnaire was sent recommended the following receivers for use in the IGS network. Prices are approximate list prices for receivers without antennas. Leica, Trimble, and Topcon indicated that reduced prices are available for educational or non-profit organizations.

*Septentrio:* PolaRx3 (\$9,750)

*Trimble:* NetR5 (\$20,000) or NetRS (\$16,000)

*Leica:* GRX1200 GG Pro (\$22,000)

*Topcon:* Net-G3 (\$18,500)

Responses in the questionnaire should be understood to refer respectively to these receivers unless otherwise noted. The questionnaire and responses follow:

**Timing considerations.** In order to combine measurements from receivers made by different vendors, the IGS needs to know how (1) the measurement epoch, and (2) the measurement interval are defined for each receiver.

- (1) The RINEX 2 definition of the measurement epoch is “The time of the measurement is the receiver time of the received signals. It is identical for the phase and range measurements and is identical for all satellites observed at that epoch. It is expressed in GPS time (not Universal Time).” Some receivers define the measurement epoch to coincide with the C/A code boundary of one of the signals being tracked. Other receivers define the epoch to coincide with integer seconds per the receiver clock. Still other receivers define the phase and pseudorange measurement times separately (contra the RINEX definition above). Please describe your definition of measurement time.

*Septentrio:* Septentrio receivers define the epoch to coincide with integer seconds per the receiver clock (or fraction thereof if the measurement rate is higher than 1 Hz). The definition is fully compliant with the RINEX standard.

*Trimble:* Trimble's receivers are fully compliant to the RINEX 2(and 3) standard

*Leica:* The Leica System1200 receiver engine is fully compliant to the RINEX standard.

*Topcon:* Topcon receivers are fully compliant to the RINEX standard. Epoch time is referenced to receiver clock and is always within 0.5 milliseconds from GPS time. Clock correction (receiver clock offset) observable is available in native format and can be output in RINEX.

- (2) The measurement interval is the interval over which the data are observed to produce phase, pseudorange, or signal power measurements. Some receivers simply sample the PLL phase estimate and the DLL code offset estimate to produce phase and pseudorange measurements, respectively. In this case, the measurement interval is given by the time constants of these two tracking loops (which go inversely as the loops' bandwidth). Other receivers use a measurement interval that is independent of the tracking loop bandwidths. For example, the JPL BlackJack receiver uses a known number of 0.02-second data intervals symmetrically arranged before and after the measurement time to obtain data for a given pseudorange (or phase or  $C/N_0$ ) measurement, and there is no correlation of noise between adjacent measurements. Please describe your definition of measurement interval and its position relative to the measurement time.

*Septentrio:* Septentrio receivers sample the continuous PLL phase, DLL code and  $C/N_0$  estimates at the measurement epoch. There is no additional fit over internal higher-rate measurements.

*Trimble:* PLL characteristics and algorithms are proprietary and of significant commercial value. Trimble does not disclose this information.

*Leica:* Leica System1200 receivers sample the continuous PLL phase, DLL code and  $C/N_0$  estimates at the measurement epoch.

*Topcon:* Topcon receivers sample the continuous PLL phase and DLL code at the measurement epoch.  $C/N_0$  estimates are obtained at 10 Hz.

**Phaselock loop characteristics.** To anticipate how well a receiver might withstand the effects of ionospheric scintillation, it is useful to know the phaselock loop update (pre-detection) interval (e.g., 1ms, 10ms, 20ms), its order (e.g., 1st, 2nd, or 3rd), and its bandwidth (e.g., 10 Hz).

*Septentrio:* The pre-detection interval and bandwidth is user selectable, with defaults being 10ms and 10 Hz respectively. A 3rd order PLL is used.

*Trimble:* PLL characteristics and algorithms are proprietary and of significant commercial value. Trimble does not disclose this information.

*Leica:* The Leica System1200 receivers pre-detection interval is not user selectable, however it automatically adjusts based on the PLL bandwidth selected by the user. The bandwidth is user selectable in a special version of the firmware available from Leica. The default is 15Hz. A 3rd order PLL is used.

*Topcon:* The pre-detection interval is not user-selectable. The bandwidth and the order are user-selectable. The default bandwidth is 25Hz and can be changed from 2Hz to 50Hz. A 3rd order PLL is used by default and can be changed to 2nd order.

**Reference oscillators.** The phase stability of a receiver depends on the stability of its oscillator. Please indicate what type of internal reference oscillator your receiver uses, whether TSXO, TCXO, OCXO.

*Septentrio:* Internal TCXO, which can be bypassed by feeding an external frequency reference.

*Trimble:* TCXO

*Leica:* The Leica System1200 receiver onboard TCXO can be slaved to an external frequency reference.

*Topcon:* Net-G3 receiver uses internal TCXO. It can be slaved to an external frequency reference (5MHz to 20MHz).

**Features.** The IGS is interested in procuring GNSS receivers that are well adapted to collecting data useful for ionospheric, tropospheric, and geodetic science applications. Please indicate whether your receiver currently supports the following features, or whether these features could be added as part of future firmware upgrades or receiver models.

- (1) Reconfiguration of tracking loops: Is it possible to change the bandwidth of the receiver's PLL and DLL? What about changing the loops' update intervals? Does this require a firmware upgrade? Can these loops be reconfigured remotely; i.e., over the network?

*Septentrio:* Bandwidth and pre-detection time can be changed by a single user-command. No firmware upgrade is needed. The command can be sent remotely like any other command of the receiver.

*Trimble:* The tracking loop bandwidths and update intervals are not configurable.

*Leica:* The Leica System1200 receiver's bandwidth for the PLL and DLL can be changed through the firmware (a special firmware can be provided to do this). The pre-detection time cannot be changes through a user command (a firmware change would be required).

*Topcon:* Tracking loops' update intervals are not configurable. The bandwidth can be changed remotely and this does not require a firmware upgrade. The bandwidth of PLL can be changed from 2Hz to 50Hz, DLL from 0.1Hz to 50Hz.

- (2) Can firmware upgrades be delivered over the network to a remote receiver?

*Septentrio:* Yes in future firmware upgrades.

*Trimble:* Firmware upgrades for the Trimble NetRS, NetR3, and NetR5 can be delivered and implemented via Ethernet.

*Leica:* Yes, either via the web interface or Leica GNSS Spider or via our proprietary LB2/OWI interface.

*Topcon:* Yes.

- (3) At what frequency can the receiver measure the amplitude (or  $C/N_0$ ) and phase of each signal being tracked (e.g., 10 Hz, 20 Hz, 50 Hz). If less than 50 Hz, can the rate be increased to 50 Hz via a firmware upgrade or otherwise?

*Septentrio:* 50 Hz.

*Trimble:*  $C/N_0$  is measured at 10 Hz in the NetR5. Phase measurements occur at a maximum rate of 20 Hz.

*Leica:* The C/No update rate is 20Hz. It would require a special version of the firmware to support a higher rate such as 50Hz.

*Topcon:* Net-G3 receiver can measure the phase of each signal at 20Hz. The  $C/N_0$  update rate equals to 10Hz. It requires a special version of firmware to support 50Hz update rate. Future Topcon receivers will have 100Hz update rate option.

- (4) Does your receiver support L2C tracking? If so, does it track both the L2CM and L2CL codes? If the L2CL code is tracked, is this done with a non-squaring PLL?

*Septentrio:* Yes, L2C is tracked in the optimal mode (i.e. tracking L2CL with a non-squaring PLL).

*Trimble:* The NetR5 supports L2C tracking. It is user configurable to provide L2CM, L2CL, or L2CM+L2CL.

*Leica:* Yes, the Leica System1200 receiver supports L2C tracking. We track both L2CM and L2CL codes. In the current firmware L2C tracking is aided by L1 tracking. Future receivers will have independent L2C tracking.

*Topcon:* Yes, Net-G3 receiver supports L2C tracking (both L2CM and L2CL). In the future version of firmware it can be configured to track either L2CM, or L2CL (or both of them).

- (5) Does your receiver support L5 tracking?

- Septentrio:* Yes, it can be configured in L1/L2 mode, or L1/L5 mode. The PolaRx3 does not support concurrent tracking of L2 and L5. Future receiver models (PolaRx4) will.
- Trimble:* The NetR5 supports L5 tracking.
- Leica:* Currently the System1200 does not support L5. The receiver hardware will be available in 2009. All existing System1200 receivers may then be upgraded to support L5 and Galileo with a board exchange.
- Topcon:* Net-G3 receiver hardware is capable of tracking of L5 signal. A firmware upgrade is required for getting L5 tracked.
- (6) Does your receiver support P-code tracking on L1 and L2? Does it produce P-code-based pseudorange measurements on both L1 and L2? Do you intend to support P-code tracking even after L5 becomes fully available?
- Septentrio:* Tracking is performed on P1 and P2, but only P-L2 measurements are output. We have no plan to discontinue the support of P-code tracking.
- Trimble:* The NetR5 does not support full P-code tracking by fully decrypting Y code signals. P-code based measurements are only available for L2. There are no plans to reduce the data available from Trimble's GNSS Infrastructure receivers as additional signals become available. Trimble designs the receiver to track and stream all available signals and provides the end user with the option to configure reduced tracking or streaming to suit their particular application.
- Leica:* The Leica System1200 engine tracks P-code on L2 only. We have no plan to discontinue the support of P-code tracking.
- Topcon:* Topcon receivers support P-code tracking on L1 and L2, thus carrier phases and pseudoranges on both L1 and L2 bands can be measured. There are no plans to reduce this functionality in future Topcon receivers.
- (7) Which Galileo signals do you intend to support, and when do you anticipate that your receivers will be capable of doing so?
- Septentrio:* Current solutions: PolaRx3: E5a, L1B and L1C, all in view.  
GeNeRx: all types of GIOVE and Galileo signals, limited to 4 satellites. Future: we are planning to support full E5 and possibly E6 for all satellites in view, but this capability may not be available until 2010, or thereafter.
- Trimble:* Which signals we intend to support is proprietary. This will depend on the commercial availability of Galileo signals.
- Leica:* The next generation of measurement engine will support L1/L2/L5 GPS + L1/L2 GLONASS + E1/E5a/E5b/Alt-BOC. The receiver hardware will be available in 2009. All existing System1200 receivers may then be upgraded to support Galileo and L5 with a board exchange. A firmware update will be required to enable the Galileo tracking when the constellation is large enough (e.g. 2 satellites) to justify it.
- Topcon:* Net-G3 receiver can already track E1/E5a signals from GIOVE satellite with a special version of firmware. Future Topcon receivers will track all Galileo signals.
- (8) Which GLONASS signals do you intend to support, and when do you anticipate that your receivers will be capable of doing so?
- Septentrio:* PolaRx3 currently supports L1-C/A, L2-P. We also intend to incorporate L2-CA.
- Trimble:* NetR5 currently supports GLONASS L1 C/A & P, L2 C/A & P.
- Leica:* The Leica System1200 engine supports L1-CA and L2-P. We can use L2-CA with a firmware change.
- Topcon:* All Topcon receivers can track GLONASS signals. Net-G3 receiver currently supports L1 C/A & P, L2 C/A & P GLONASS signals.
- (9) Are the contents of your receiver's binary output completely specified in documentation that the user can obtain? (This is required for data conversion to the latest RINEX format).

*Septentrio:* Yes, and additionally a Binex (open source) format conversion software tool for our receivers is currently being created by NR Canada for IGS use.

*Trimble:* The NetR5 offers various binary outputs, both proprietary and publicly specified. Most RINEX format files can be produced from an RTCM3.0 data stream. Trimble has previously made proprietary message formats available to customers needing this information for their application but makes no promise that this is always possible.

*Leica:* Yes, we provide the proprietary LB2/OWI interface of our receivers to customers.

*Topcon:* Yes. A software tool for conversion of TPS-files to RINEX is provided. TPS files can also be converted to RINEX with current version of teqc from UNAVCO.

- (10) Can the code running on your baseband processor be obtained under a license? If so, what is the approximate cost of the license?

*Septentrio:* This option is available, dependent upon the user requirements and potential license restrictions. Prices have not yet been established for this option.

*Trimble:* Baseband processor code cannot be purchased from Trimble.

*Leica:* No, not at this time.

*Topcon:* No, not for current receivers.

## 5. SOFTWARE GNSS RECEIVERS

One of the long-term goals identified in the 2008-2012 IGS strategic plan is to “incorporate and integrate new systems, technologies, applications and changing user needs into IGS products and services.” In keeping with this goal, the authors believe the IGS should keep a close watch on the development of software GNSS receivers and possibly incorporate software receiver technology into future IGS reference stations.

Software GNSS receivers (also known as software-defined receivers) differ from traditional GNSS receivers in that they do not depend on any special-purpose ASIC chips. Instead, a software receiver implements all digital signal processing functions (i.e., those downstream of its analog RF front end)—from correlation to navigation solution—in software reprogrammable FPGAs, DSPs, or general-purpose microprocessors. The advantages in flexibility that software receivers offer, coupled with ever-more-powerful processors, suggest that software receivers will have an expanding presence in future specialty GNSS applications like those supported by the IGS.

The following section gives an overview of software GNSS receiver prospects from an IGS perspective. Thereafter, reports on the status of three significant software receiver development efforts are given.

### 5.1. Outlook.

#### 5.1.1. Favorable Aspects.

**Reconfigurability:** All signal processing downstream of digitization is completely reconfigurable on a software GNSS receiver. Hence, software receivers can readily support non-standard observables and tracking loops, internal cycle slip detection and mitigation, and other adaptations interesting to the IGS.

**Transparency:** The software receiver development effort at Cornell University has plans to license the complete receiver source code to academic and scientific organizations. The JPL receiver has precisely and openly defined measurement techniques. The commercial version of the University FAF Munich receiver, the IFEN GmbH NavX(R)-NSR, offers sockets into which users can plug their own tracking loop code. All of these approaches allow users to accurately model the receiver products.

**Performance:** Because software receivers can emulate the behavior of the special-purpose ASICs used in GNSS receivers—indeed, it is common industry practice to develop an FPGA-based functional prototype of an ASIC before fabrication—the performance limits of software receivers are no different from those of traditional receivers.

### 5.1.2. *Unfavorable Aspects.*

**Lack of P(Y) tracking:** Besides the JPL software receiver, which employs FPGAs to support high-sample-rate correlations, no other software GNSS receiver of which the authors are aware is currently capable of codeless or semicodeless tracking of the P(Y) signal on L1 or L2. Given that this capability is expected of IGS receivers until Event A2 in the minimum requirements schedule proposed in this paper (cf. Section 3.1), this represents a significant drawback. Of course, software receiver development efforts may include some kind of semicodeless P(Y) tracking in future versions; however, to avoid intellectual property conflicts and to make best use of limited computational resources, developers are less interested in the encrypted Y-code signals than in the modernized GNSS signals.

**Inadequate testing:** For software receivers to gain a foothold in the IGS network or in any other precision application they will have to undergo extensive comparison testing against more familiar traditional receivers. A comparison like the one conducted in [2] would be a useful preliminary test. Thereafter, several software receivers should be co-located with current receivers at IGS sites and their residuals, multipath performance, and day boundary discontinuities should be examined just as for other IGS receivers.

5.1.3. *Unknowns.* Questions remain about how software receiver development will progress and how (and if) software receivers will be incorporated into the IGS network. One could think of these unknowns as unfavorable aspects, but they are more aptly categorized as simply unknowns.

**Hardware platforms and software:** Who will build the hardware platforms that support software receivers? Who will provide the software, support, and maintenance? In the most likely scenario, a commercial provider will sell platforms to the IGS and provide software licenses and support.

One candidate, ASTRA LLC ([www.astraspace.net](http://www.astraspace.net)) has plans to license the Cornell dual-frequency receiver code and build platforms to support it. ASTRA LLC may be willing to sell receiver platforms separately from the software license and maintenance package. In this case, the IGS may wish to obtain a software license—which would presumably be free for academic and science users—directly from Cornell. However, Cornell would not provide software maintenance or support. Hence, if the IGS chose this option, it would have to assume the responsibility of tailoring the code for IGS applications and maintaining it. Code maintenance could be centralized or could be distributed among the various IGS Analysis Centers.

Another vendor, IFEN GmbH ([www.ifen.com](http://www.ifen.com)), sells a commercial version of the University FAF Munich receiver. IFEN GmbH sells its 10 MHz L1 front-end, the software receiver executable, and the application programming interface (API) separately. Along with the API comes C/MATLAB source code, which could be the basis for future IGS software receiver development. A multi frequency front-end is in development.

**Price:** What will be the cost of commercial software receiver platforms, software licenses, and maintenance contracts? Will per-unit costs be competitive with those of traditional receivers from established vendors? ASTRA LLC has plans to offer a dual-frequency (L1 C/A and L2C) platform for approximately \$1,200. Software licensing and a maintenance contract will likely be sold separately, with the per-unit cost of the software license and maintenance contract being quite small (a few hundred dollars) for lots of 10 receivers. Approximate prices for the separate components of the IFEN GmbH NavX(R)-NSR receiver are not currently known.

## 5.2. Status of Significant Software GNSS Receiver Development Efforts.

5.2.1. *Cornell University.* Cornell University has developed the GRID receiver (GNSS Receiver Implementation on a DSP) with the goal of using tens or hundreds of GRID receivers to do dense-array-based ionospheric imaging. The GRID receiver, shown in Fig. 8 was formerly an L1 C/A-only receiver (see [3])





FIGURE 8. The Cornell University GRID (GNSS Receiver Implementation on a DSP) instrument.

for a writeup) but is currently undergoing a conversion to dual-frequency (L1 C/A and L2C) capability. The receiver is implemented on a Texas Instruments DSP and can operate as a stand-alone device. It includes advanced tracking loops specially designed for robustness in the presence of ionospheric scintillation.

The Cornell development team hopes to be awarded Phase II funding from an AFOSR STTR program. If awarded, the funding will allow the team to develop the GRID into a commercializable, internet-ready, fully-reprogrammable, dual-frequency, low-cost, software GNSS receiver.

5.2.2. *University FAF Munich.* Software GNSS receiver development at the University FAF Munich started in 2002. It has been funded by the German Armed Forces (BWB, AGeoBw), the DLR and ESA. The current receiver, a screenshot of which is shown in Fig. 9, is capable of tracking all-in-view civil GPS, SBAS and Galileo signals with a high accuracy on L1/L2 and L5. Processing of the encrypted P(Y)-code signal has not yet been done in real time. The approach pursued at the University FAF is based on the following key elements: a software architecture which supports multiple CPU cores to do signal tracking in parallel, a tracking scheme based on code continuous reference waveforms (CCRW) which allows multipath mitigation and is flexible with regards to the used sampling frequency, a dynamic sample rate reduction scheme which is employed when the received signal power is high and the contribution of thermal noise to the error budget is negligible. Most importantly, optimized assembly language routines streamline the signal processing required for correlation and acquisition.

5.2.3. *NASA's Jet Propulsion Laboratory (JPL).* As part of NASA's Instrument Incubator Program, the GNSS receiver group at JPL has built a prototype instrument, TOGA (Time-shifted, Orthometric, GNSS Array), to address a variety of GNSS science needs (see Fig. 10). The TOGA receiver design features several innovative capabilities:

- (1) Multiple FPGAs to provide reprogrammable digital signal processing logic.
- (2) Buffer memory to store sampled data for either near-realtime onboard processing or processing offline on one of JPL's software receivers.
- (3) An electronically steered antenna (ESA) array which forms simultaneous beams in multiple directions for L1, L2, and L5 frequencies to increase signal gain and suppress multipath.
- (4) A Linux operating system based science processor serves as experiment scheduler and data post-processor to ease scientist-developed infusion of new algorithms.

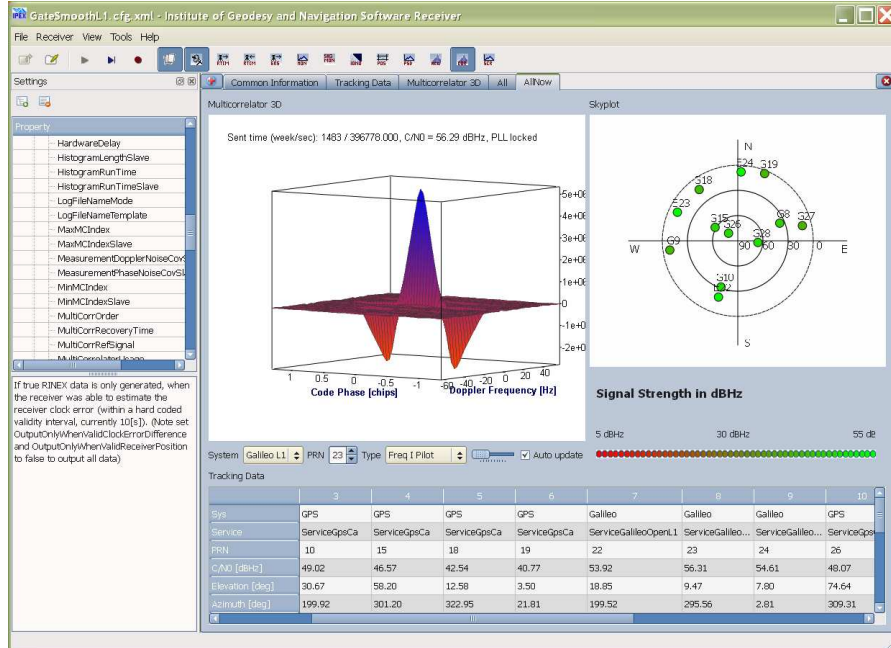

FIGURE 9. University FAF software receiver in GPS/Galileo mode.

The first TOGA engineering model receiver has been built and demonstrated by forming multiple beams and, in post-processing, tracking L1 and L2 signals, L5 from a WAAS SBAS satellite, E1 from GIOVE-A, and E1 and E5a from GIOVE-B.

## 6. RECOMMENDATIONS

- (1) Study the effects of long-delay multipath by comparing co-located dual-frequency P(Y)-code-based measurements with dual-frequency C/A- and L2C-based measurements (cf. Section 2.2.1).
- (2) Adopt the minimum IGS receiver requirements schedule outlined in Section 3.1.
- (3) Request from commercial receiver vendors either (1) a detailed measurement description, or (2) adoption of a standardized measurement technique (cf. Section 4.1.2).
- (4) Compare the performance of at least one software GNSS receiver against that of a traditional receiver via signal simulator tests (such as those conducted in [2]) and via co-location with traditional IGS receivers (cf. Section 5.1.2).
- (5) Establish an IGS format for exchange of digitally-sampled IF data (i.e., the data stored to disk by digital storage receiver like the one schematized in Fig. 7).
- (6) Form an IGS Software Receiver Working Group.

## REFERENCES

- [1] K. T. Woo, "Optimum semi-codeless carrier phase tracking of L2," in *Proc. ION GPS 1999*. Nashville, Tennessee: Institute of Navigation, 1999.
- [2] O. Montenbruck, M. Garcia-Fernandez, and J. Williams, "Performance comparison of semicodeless GPS receivers for LEO satellites." *GPS Solutions*, vol. 10, pp. 249 – 261, 2006.
- [3] T. E. Humphreys, B. M. Ledvina, M. L. Psiaki, and P. M. Kintner, Jr., "GNSS receiver implementation on a DSP: Status, challenges, and prospects," in *Proceedings of ION GNSS 2006*. Fort Worth, TX: Institute of Navigation, 2006.



FIGURE 10. JPL's TOGA (Time-shifted, Orthometric, GNSS Array) instrument.